

Outside the Box Competition – Signal Box Art for Downtown Ponca City

Hosted by Ponca City Main Street

Deadline: Friday, June 2nd, by 5:00 p.m.

Artist's Award: \$250 per selected design

A. PROJECT SUMMARY

Ponca City Main Street (PCMS) is seeking submissions for artwork to infuse art, color and creativity into our downtown landscape. Artwork chosen will be transferred to vinyl wraps by a local contractor and installed on traffic signal boxes in our historic downtown district. Initially, PCMS plans to install wraps on 3 signal boxes. If successful, artwork may be added to additional signal boxes in the district.

B. SIGNAL BOX DIMENSIONS

Artists should plan to cover three sides of the box – two side panels at 44 ½” by 16 ½” and one front panel at 44 ½” by 30”, or, alternatively, one solid panel at 44 ½” by 64”. Note example in top right hand corner.

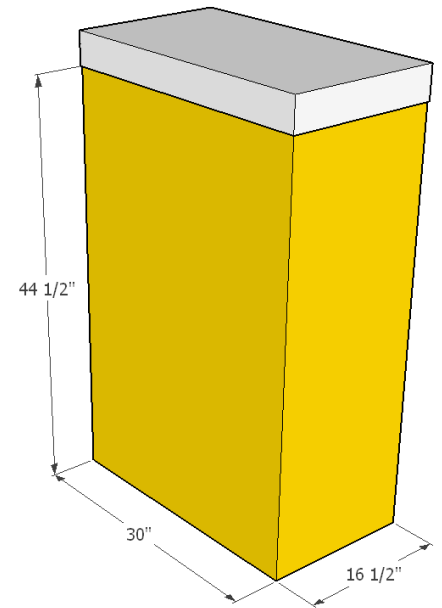

C. HOW TO APPLY

Applicants must submit their entry via Dropbox or Google Drive and can send entries to the email address below. Submissions must be received by 5:00 p.m., Friday, June 2, 2017. Late or incomplete submissions will not be considered. **Include with submission:** Name, address, email, phone number, name & description of artwork.

D. DESIGN CRITERIA

1. All final files must be submitted at full size, 300 dpi. Any text included in the design must be outlined and embedded. Include a 2” bleed. Color should be CMYK. File Formats accepted are: Illustrator CS as .ai or .pdf.; a comparable SVG file; or a full size fully rastered JPG.
2. Designs are open to each artist’s vision, but the color and design should be visually effective from a distance.
3. Artwork must be original and may not be work that has been sold or reproduced in any way.
4. Artists must use the dimensions provided when creating each design; note signal box example above.
5. Designs may not contain any representations of traffic lights, signs, or signals.
6. Designs may not advertise or promote a business, product or viewpoint.
7. Designs may not include any breach of intellectual property, trademarks, brands, or images of illegal activity.
8. Designs should be appropriate for viewers of all ages.
9. The finished artwork will be in public domain and therefore may be subject to vandalism. Accordingly, artists should be thoughtful about having large open areas in the design which might provide an opportunity to deface the work.
10. Artists are encouraged to sign their work, though a signature is not required.

E. SELECTION PROCESS

PCMS will review all submissions and select designs. Payment will be made upon completion of an accepted design that fits the template and execution of an agreement authorizing the use of the artwork as described below under “Use of Design”. PCMS reserves the right to reject any or all designs and re-advertise, and to accept the design or designs that best benefit PCMS. PCMS is not responsible for costs associated with preparing designs in response to this call for art.

F. USE OF DESIGN

Artists submitting artwork understand and agree to the following: Selected design will be digitally applied to vinyl wrap and installed on a city-owned traffic signal box. The Contractor may make adjustments to the finished piece as needed to make the design fit the signal box. The artwork will be installed outside on a functioning piece of equipment and may be vandalized, destroyed by weather, damaged or removed. PCMS may reproduce and reinstall the artwork; however PCMS has no obligation to maintain the artwork or to allow the artist to maintain the artwork. Vinyl wraps typically last 5-7 years, but installation time is not guaranteed by PCMS. Artists must sign an agreement authorizing PCMS to install the artwork and to use the images of the artwork, with attribution, and also to promote PCMS, the PCMS Design Committee and the potential Grand Arts District.

INQUIRIES & SUBMISSIONS

All questions should be directed to:

Ponca City Main Street, Chelsea McConnell

clmccConnell@poncacitymainstreet.com (580) 763-8082

516 E. Grand Ave., Ponca City, OK 74601

Thank you for your consideration in creating art for our community. PCMS believes in the power of art and its ability to improve a place. It is our hope that this project will help further beautify our downtown.